

FEATURES

- > Compact design
- > Quick change of cassette (SR10)/tubing (SR25, SR18)
- > Endless tubing possible (SR10)
- > Self priming
- > Safe to run dry
- > Maintenance free
- > Different tubing materials

TYPICAL APPLICATIONS

- > Chemical industry
- > Medical industry
- > Laboratory and analysis technology
- > Food sector
- > Hygiene, disinfection
- > Industrial dishwasher
- > Glass washing

BASE MODEL

SR10/30

SR10/50

SR10/100

SR18

SR25





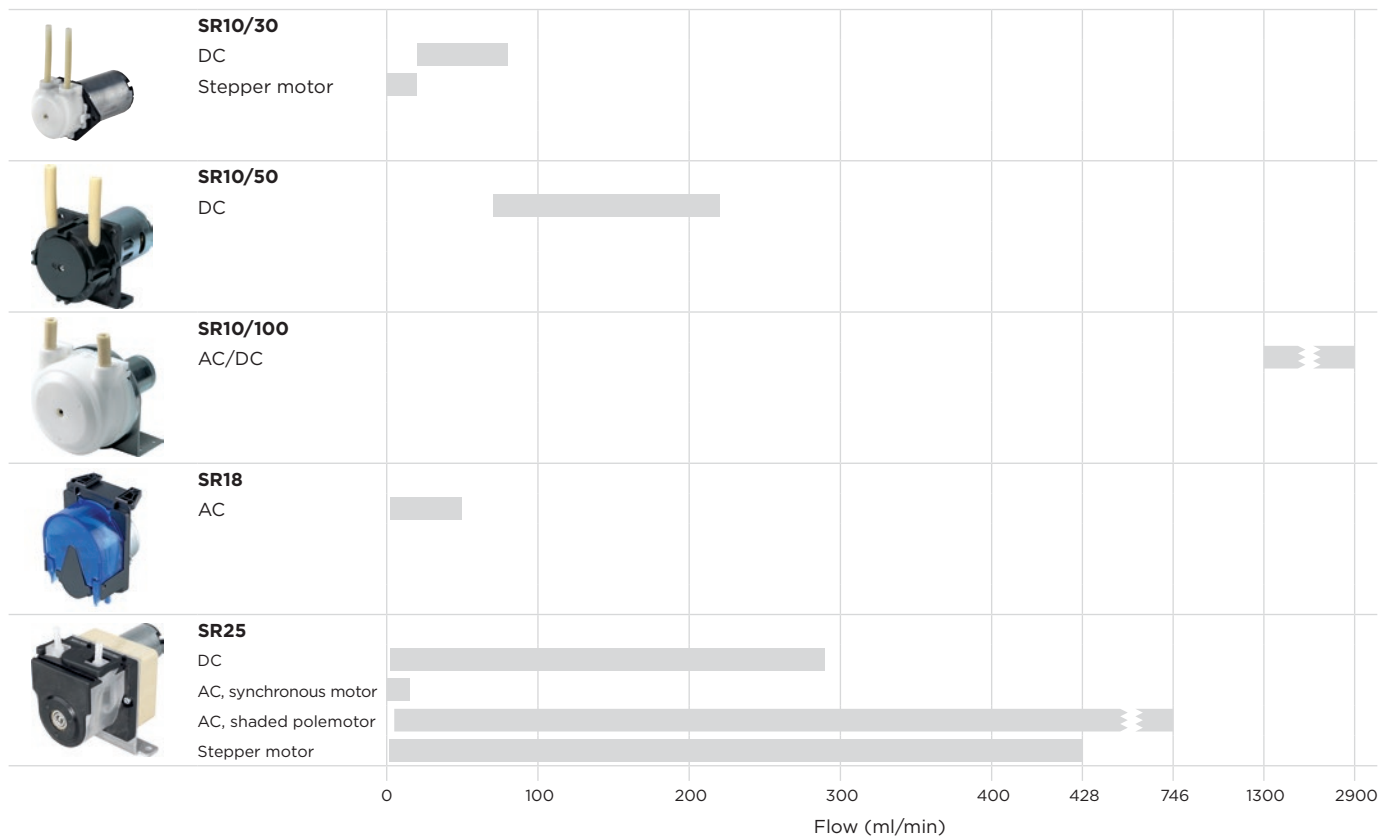

Peristaltic

Peristaltic Pumps

CHARACTERISTICS OVERVIEW



PRESELECTION

		Drive				Operation mode		Stand-by pump		Page
		12/24 V DC	12/24 V DC LC motor	230 V AC	Stepper motor	Continuous operation	Short time operation	IP54	IP54, adjustable	
	SR10/30	●	●		●		●			5 - 7
	SR10/50		●				●			8
	SR10/100	●		●			●	●		9
	SR18			●		● ¹⁾	●			11
	SR25	●		●	●	●	●		●	12 - 17

¹⁾ pumps with sequencer

Peristaltic Pumps

SERIES SR10



- Speed reduction through frictional connection from the motor shaft to the rollers.
- Very simple construction with the use of few parts only.
- Easy change of the cassette.
- Generally 3 rollers.
- For short time operation only.
- If the pump is stored longer than three months, we recommend to take the cassette off the motor shaft and store it separately.
- Different motors available (DC, low cost DC, AC and stepper motor).

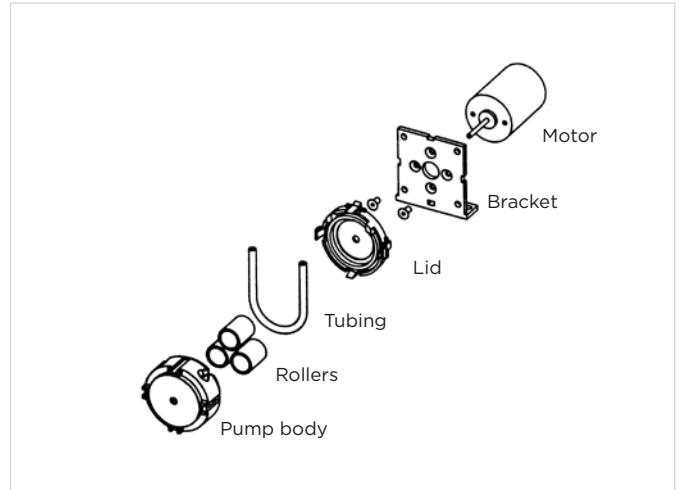

SERIES SR18



- Peristaltic pump with QuiXchange system
- Tube exchange without tooling within seconds
- Spring loaded roller carrier with two rollers for extremely long durability
- Optional „sequencer“ for flow adjustment
- AC-motor

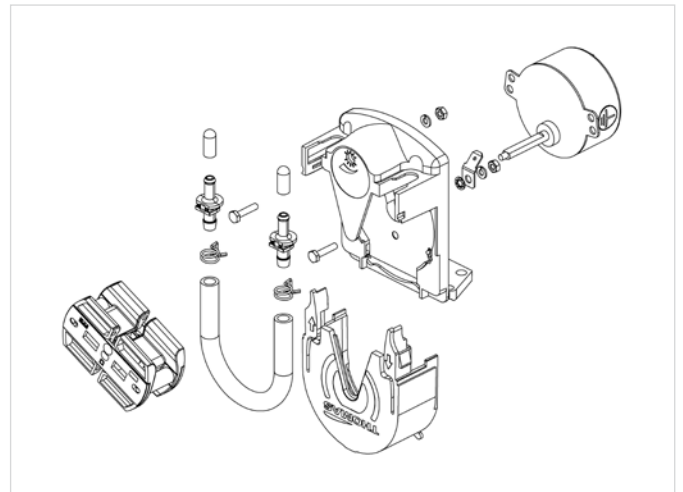

SERIES SR25



- Protection of the tubing due to spring loaded rollers and guiding side rollers.
- Quick and easy change of the tubing.
- Roller carrier with two rollers.
- Also suitable for continuous operation, depending on the drive.
- If stored longer than three months, we recommend to remove the tubing.
- Different gear motors available (DC, AC and stepper motor).

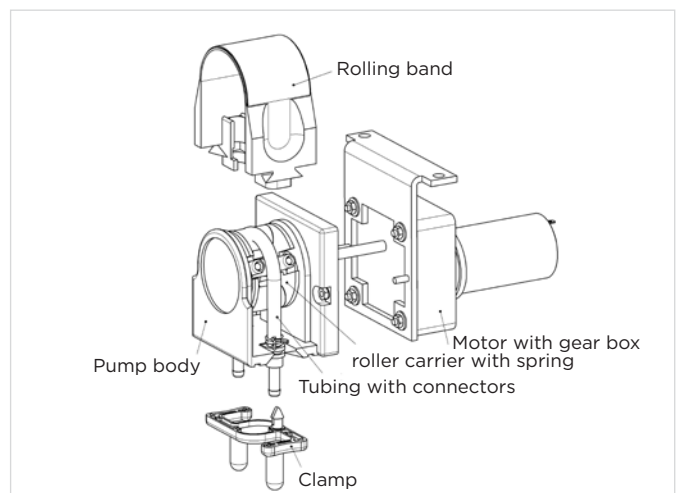

Peristaltic Pumps

DUTY CYCLES

SR10

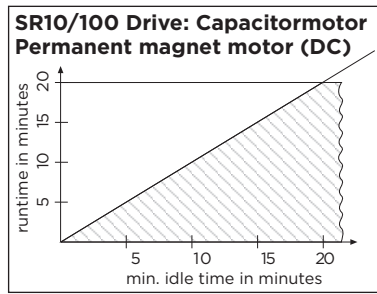
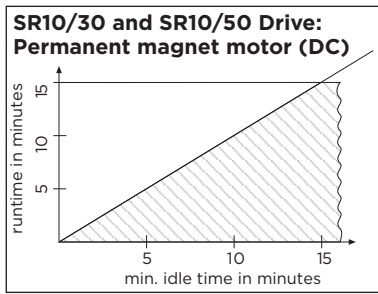

SR18

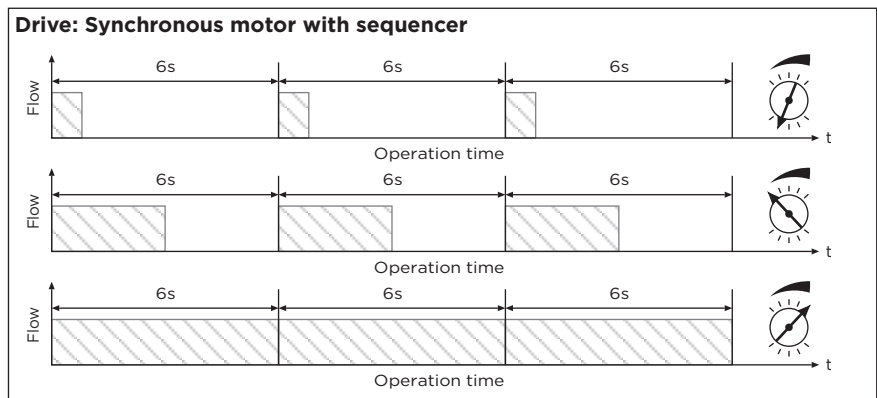
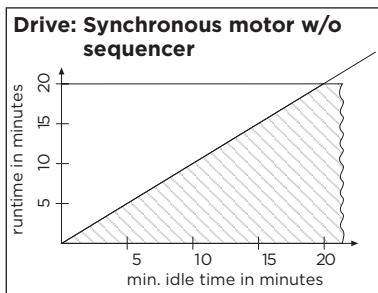

SR25

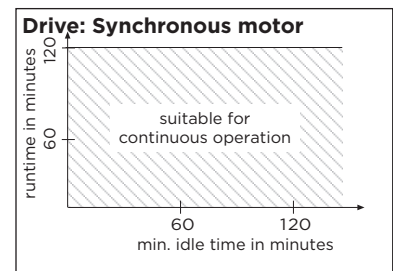
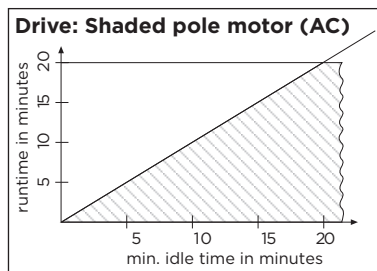
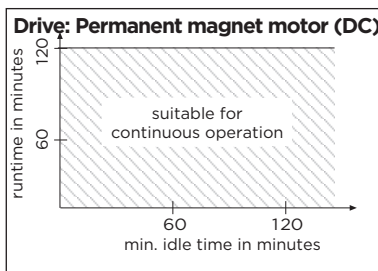

DUTY CYCLES	SR10			SR18	SR25	
	SR10/30	SR10/50	SR10/100	SR18 - 15 rpm	SR25 - 10 rpm	SR25 - 500 rpm
Lifetime of the tubing						
Novoprene	500 h	500 h ²⁾	200 h	4000 h	> 5000 h	500 h
Norprene®						
PharMed BPT®						
Silicone	200 h	200 h	-	500 h	500 h	100 h
Other wearing parts						
Roller carrier	Change the complete cassette ¹⁾ (see lifetime of the tubing)			2500 h	> 5000 h	500 h
Rolling band/lid						

GENERAL DATA	SR10	SR18	SR25
Max. suction height	8 m H ₂ O	8 m H ₂ O	8 m H ₂ O
Max. pressure height	8 m H ₂ O	10 m H ₂ O	10 m H ₂ O
Max. ambient temperature	40 °C	40 °C	40 °C
Media temperature	50 °C (short time 90 °C)	50 °C (short t. 90 °C)	50 °C (short time 90 °C)

1) We recommend to roughen the shaft in axial direction when changing the cassette (sand paper grit size 150).

2) Ø 4 inner diameter on request

Norprene®, PharMed BPT® Norton Co. Reg. TM's

Peristaltic Pumps SR10/30

12/24 V low cost DC
For short time operation only

Flow

16 - 55 ml/min



SR10/30 DC angled fixing
(straight without drawing)

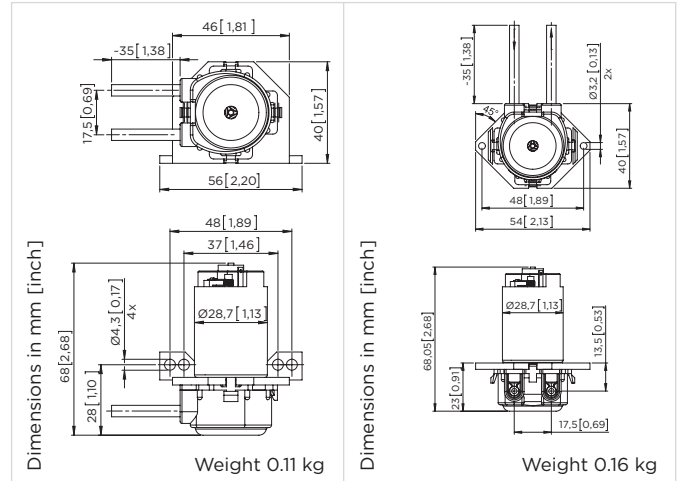

Tubing Novoprene		Tubing PharMed BPT*		Fixing	Inner tubing Ø mm	Flow ²⁾ ml/min
12 V DC	24 V DC	12 V DC	24 V DC			
		20300512	20300542	straight	1.0	16
		20300513	20300543	angled		
20300314	20300344	20300514	20300544	straight	1.5	28
20300315	20300345	20300515	20300545	angled		
20300316	20300346			straight	2.0	38
20300317	20300347			angled		
20300318	20300348	20300235	20300237	straight	2.5	55
20300319	20300349	20300236	20300238	angled		

Tubing Silicone		Fixing	Inner tubing Ø mm	Flow ²⁾ ml/min
12 V DC	24 V DC			
20300412	20300442	straight	1.0	16
20300413	20300443	angled		
20300414	20300444	straight	1.5	28
20300415	20300445	angled		
20300416	20300446	straight	2.0	38
20300417	20300447	angled		
20300418	20300448	straight	2.5	55
20300419	20300449	angled		

2030... Stock programme

Current consumption depending on the tubing diameter,
at free flow and nominal voltage

12 V DC:	180 - 300 mA
24 V DC:	90 - 150 mA

2) Note: The indicated values are average measured with water.
The actual values depend on different parameters like quality and age of tubing, pressure of tubing beds, pressure ratios, viscosity.
Please see page 4 for recommended running times and general data.

Peristaltic Pumps SR10/30

12/24 V Direct current motor
For short time operation only

Flow

20 - 80 ml/min

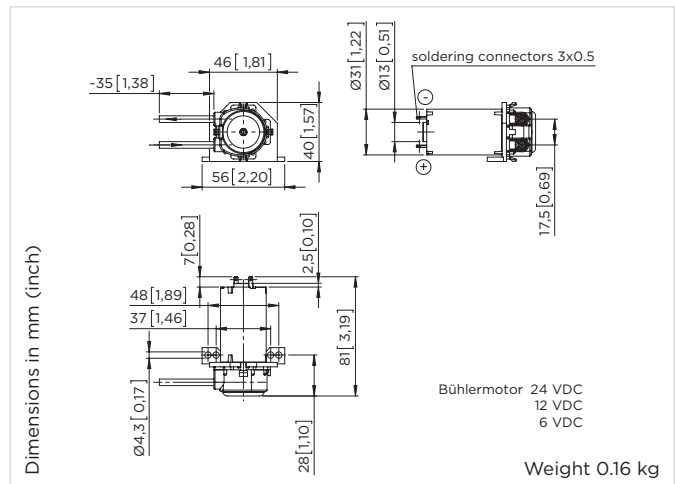
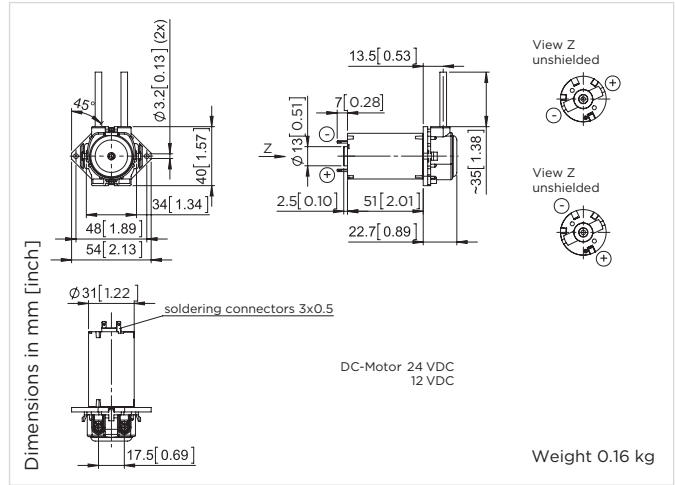

Tubing Novoprene ¹⁾		Fixing	Inner tubing Ø mm	Flow ²⁾ ml/min
12 V DC	24 V DC			
		straight	1.0	20
		angled		
20300122	20300130	straight	1.5	37
20300126	20300134	angled		
20300123	20300131	straight	2.0	55
20300127	20300135	angled		
20300124	20300132	straight	2.5	80
20300128	20300136	angled		

1) other tubing materials on request

Current consumption depending on the tubing diameter,
at free flow and nominal voltage
12 V DC: 180 - 300 mA
24 V DC: 90 - 150 mA

2) Note: The indicated values are average measured with water.
The actual values depend on different parameters like quality and age of
tubing, pressure of tubing beds, pressure ratios, viscosity.
Please see page 4 for recommended running times and general data.

Peristaltic Pumps SR10/30

24 V DC with stepper motor
For short time operation only
Circuit board recommended for test purposes

Flow | **0.5 - 20 ml/min**

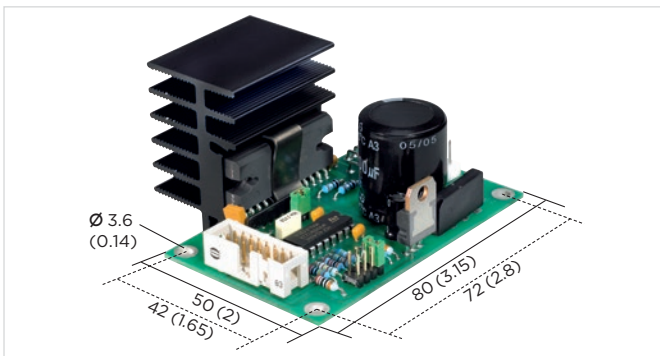
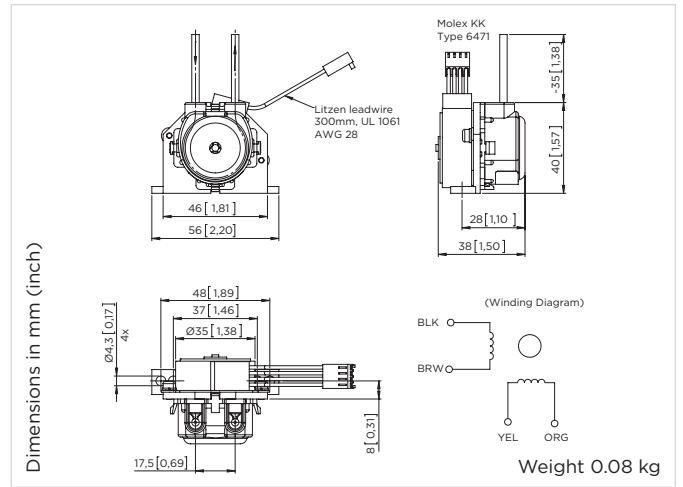

4 possible operating methods

- internal speed selection via jumper – option with wiring set¹⁾
- external speed selection
- analog input via pc
- digital input (clocked pulse)

Features

- speed pre-selection
- clockwise, counter clockwise operation
- instant priming
- selective operating method

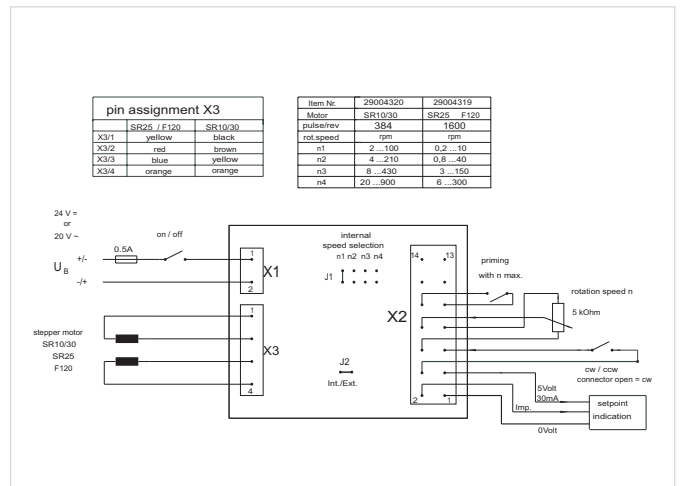

Adjustable range	I	II	III	IV
Speed	4 - 100 rpm	8 - 210 rpm	16 - 430 rpm	40 - 900 rpm

Tube Pharmed BPT*	Max. flow ²⁾ ml/min (adjustable range 4 - 100%)			
Ph 1.0 x 1.1	0.5	1	2	4
Part number - pump without circuit board				20301012
Part number - pump with circuit board				20301002
Ph 1.5 x 1.1	1	2	5	10
Part number - pump without circuit board				20301013
Part number - pump with circuit board				20301003
Ph 2.5 x 1.0	2	5	10	20
Part number - pump without circuit board				20301014
Part number - pump with circuit board				20301004

Electrical Data	Max. flow ²⁾ ml/min (adjustable range 4 - 100%)
Nominal voltage (drive through electronic board)	24 V/DC oder 20 V/AC
Motor	Stepper motor, bipolar, stepping angle 7.5°
Current consumption	0.4 A
Max. restart consumption	3 A*
Inductance at 1 kHz, 1 V	13 mH
Winding resistance	13 Ω

* Delay fuse to be used.

1) Option: 14-pole connecting cable with plug, rocker switch for clockwise and lefthanded running Potentiometer and speed-push-button, part number 29000702

2) Note: The indicated values are average measured with water. The actual values depend on different parameters like quality and age of tubing, pressure of tubing beds, pressure ratios, viscosity. Please see page 4 for recommended running times and general data.

Peristaltic Pumps SR10/50

12/24 V Direct current motor
For short time operation only

Flow 52 - 220 ml/min

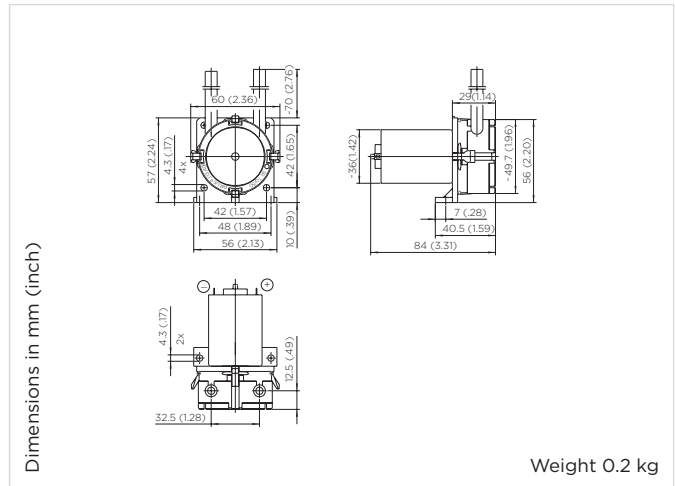

Tubing Novoprene		Tubing PharMed BPT [®]		Tubing dimensions	Flow ²⁾
12 V DC	24 V DC	12 V DC	24 V DC	mm	ml/min
20500501	20500505	20500702	20500705	2.4 x 1.6	100
20500502	20500506			3.2 x 1.6	170
20500503	20500507			4.1 x 1.6	220
		20500703	20500706	4.0 x 1.6	

Tubing Silicone		Tubing PharMed BPT [®]		Tubing dimensions	Flow ¹⁾
12 V DC	24 V DC	12 V DC	24 V DC	mm	ml/min
20500602	20500606			2.5 x 1.6	100
20500603	20500607			4.0 x 1.6	220

2050... Stock programme

1) on request in white
Option: Straight flange for flush mounting part number 20501 ...
12/24 V DC - with additional circuit board (on request)

Current consumption depending on the tubing diameter,
at free flow and nominal voltage
12 V DC: 0.4 - 0.54 A
24 V DC: 0.2 - 0.27 A

2) Note: The indicated values are average measured with water.
The actual values depend on different parameters like quality and age of
tubing, pressure of tubing beds, pressure ratios, viscosity.
Please see page 4 for recommended running times and general data.

Peristaltic Pumps SR10/100

230 V/50 Hz, 12/24 V Direct current motor
For short time operation only

Flow

1300 - 3000 ml/min



SR10/100 AC

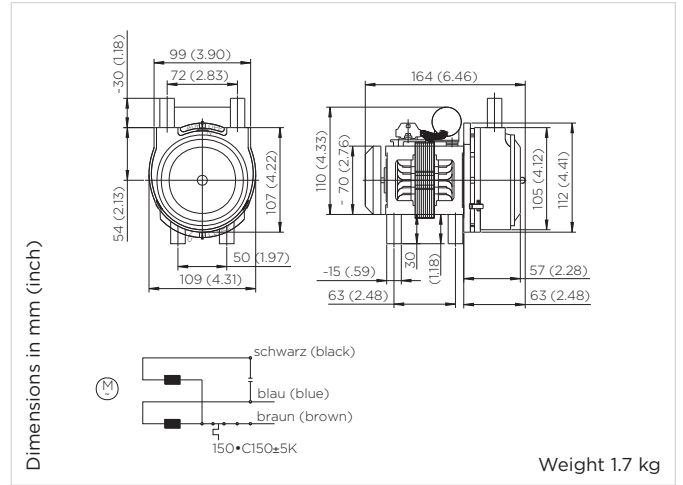

Weight 1.7 kg



SR10/100 DC With bracket

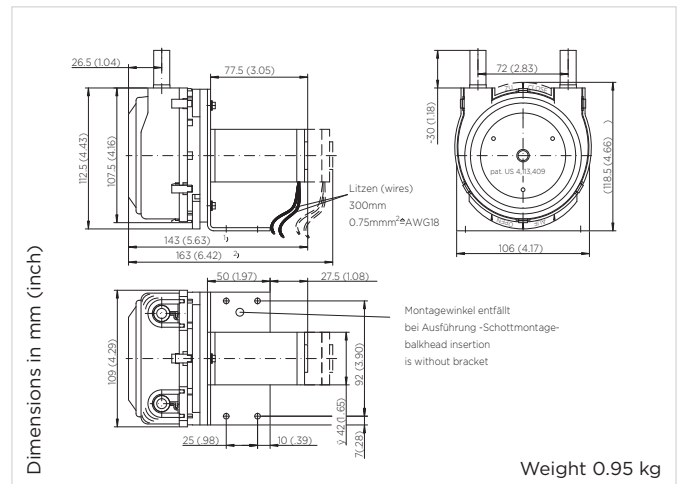

Weight 0.95 kg

Tubing Norprene ¹⁾		Fixing	Tubing	Flow ²⁾
12 V DC	24 V DC	24 V DC	dimensions mm	ml/min
21001008	21001009	bracket	8.0 x 2.4	2300
21001014	21001015	flush mount		
21001200	21001122	bracket	9.5 x 2.4	3000
21001205	21001206	flush mount		

Tubing Norprene [*]	Motor speed	Tubing dimensions	Flow ¹⁾
230 V/50 Hz	rpm	mm	ml/min
21001000	2800	6.35 x 2.4	1300
21001002	2800	9.5 x 2.4	3000

1) other tubing material on request

Option: Recommended inference suppression according to EN 55011 B (CE-conform)
 12/24 V DC - with additional circuit board (on request)

Current consumption at free flow and nominal voltage
 12 V DC: 3.0 A
 24 V DC: 1.5 A
 230 V/50 Hz: 0.4 A

2) Note: The indicated values are average measured with water.
 The actual values depend on different parameters like quality and age of tubing, pressure of tubing beds, pressure ratios, viscosity.
 Please see page 4 for recommended running times and general data.

Peristaltic Pumps SR10

Spare parts SR10 series

Model SR10/30

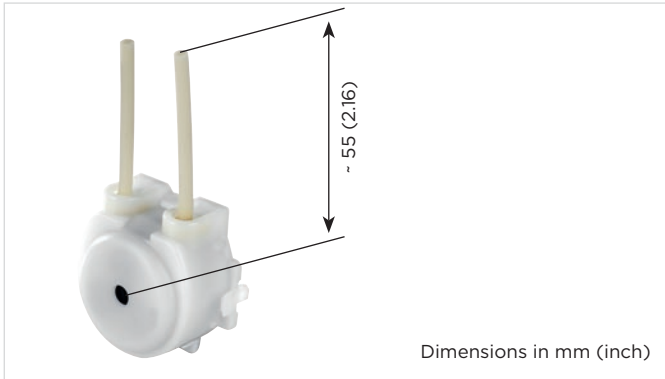

Model SR10/50

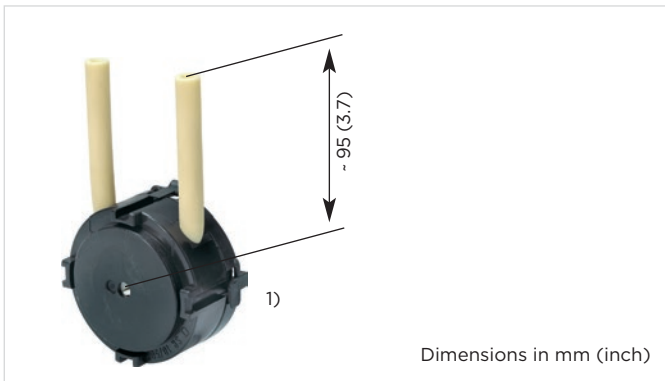

Model SR10/100

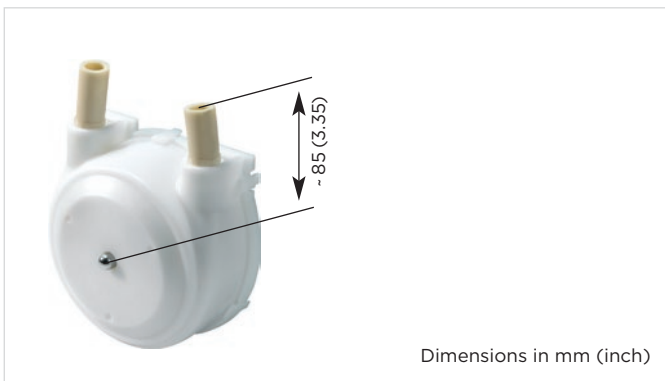

1) on request in white

	Tubing Inner Ø x Wall thickness	Drive	
		DC low cost Page 5	DC Pages 6/7
Novoprene	1.5 x 1.0 mm	92030703	92030514
Novoprene	2.0 x 1.0 mm	92030702	92030513
Novoprene	2.5 x 1.0 mm	92030701	92030704
PharMed BPT®	1.0 x 1.1 mm	92030548	92030604
PharMed BPT®	1.5 x 1.1 mm	92030534	92030549
PharMed BPT®	2.5 x 1.0 mm	92030611	92030603
Silicone	1.0 x 1.0 mm	92030800	92030505
Silicone	1.5 x 1.0 mm	92030802	92030554
Silicone	2.0 x 1.0 mm	92030804	92030555
Silicone	2.5 x 1.0 mm	92030806	92030553

Novoprene	2.4 x 1.6 mm	92050576
Novoprene	3.2 x 1.6 mm	92050577
Novoprene	4.1 x 1.6 mm	92050594
PharMed BPT®	2.4 x 1.6 mm	92050586
PharMed BPT®	4.0 x 1.6 mm	92050587
Silicone	2.0 x 1.6 mm	92050581
Silicone	2.5 x 1.6 mm	92050582
Silicone	4.0 x 1.6 mm	92050583

Norprene®	6.35 x 2.4 mm	92100512
Norprene®	8.0 x 2.4 mm	92100504
Norprene®	9.5 x 2.4 mm	92100501

Tubing dimensions
1.5 x 1.0 mm
Inner Ø Wall thickness

Peristaltic Pumps SR18 with QuiXchange System

230 V/50 Hz, synchronous gear motor
Suitable for continuous running

Flow

5 - 50 ml/min

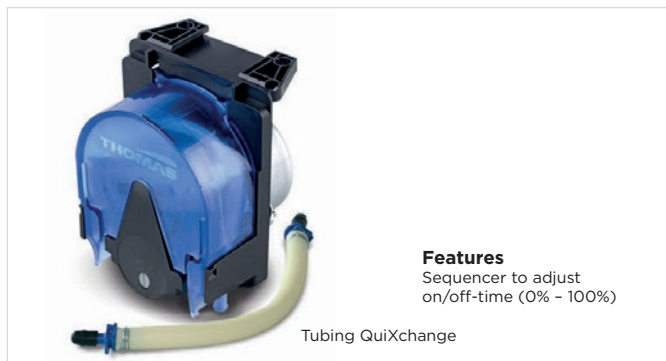

Tubing QuiXchange

Features
 Sequencer to adjust on/off-time (0% - 100%)

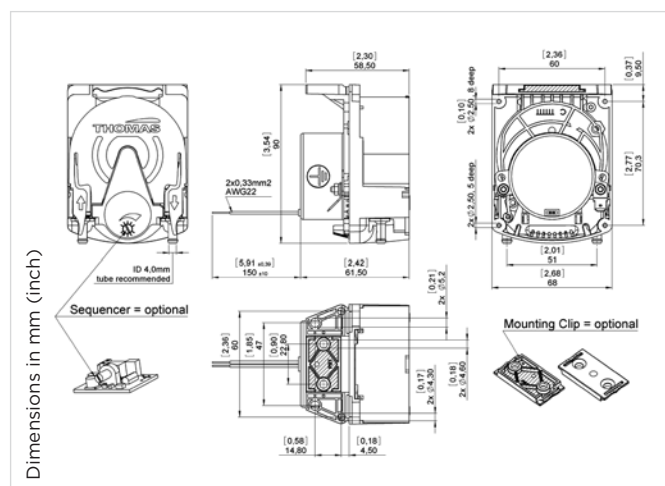

	Nominal speed	QuiXchange
	15 rpm	

Tubing Novoprene (ID x WT)	Flow ²⁾ ml/min	Tubing only
N 6.0 x 1.6 mm	50	
Part number - pump without sequencer	20180251	92018551
Part number - pump with sequencer	20181251	92018551
N 4.1 x 1.6 mm	20	
Part number - pump without sequencer	20180252	92018552
Part number - pump with sequencer	20181252	92018552
N 2.4 x 1.6 mm	10	
Part number - pump without sequencer	20180253	92018553
Part number - pump with sequencer	20181253	92018553
N 1.6 x 1.6 mm	5	
Part number - pump without sequencer	20180254	92018554
Part number - pump with sequencer	20181254	92018554

Tubing Silicone (ID x WT)	Flow ¹⁾ ml/min	Tubing only
S 5.0 x 1.6 mm	40	
Part number - pump without sequencer	20180202	92018502
Part number - pump with sequencer	20181202	92018502
S 4.0 x 1.6 mm	25	
Part number - pump without sequencer	20180203	92018503
Part number - pump with sequencer	20181203	92018503
S 2.5 x 1.6 mm	10	
Part number - pump without sequencer	20180201	92018501
Part number - pump with sequencer	20181201	92018501

Running Data		
Rotation direction	clockwise	

Electrical Data		
Voltage	230 V/50 Hz	
Motor	synchronous	
Motor insulation class	E	
Power consumption	5.5 W	

General Data		
Connector material	PP	
Weight	0.23 kg	

2018... Stock programme

2) Note: The indicated values are average measured with water. The actual values depend on different parameters like quality and age of tubing, pressure of tubing beds, pressure ratios, viscosity. Please see page 4 for recommended running times and general data.

Options: mounting clip
 compression fitting

Art. Nr. 29027360
 Art. Nr. 29027298

Peristaltic Pumps SR25

12/24 V, Direct current motor

Flow 2 - 287 ml/min

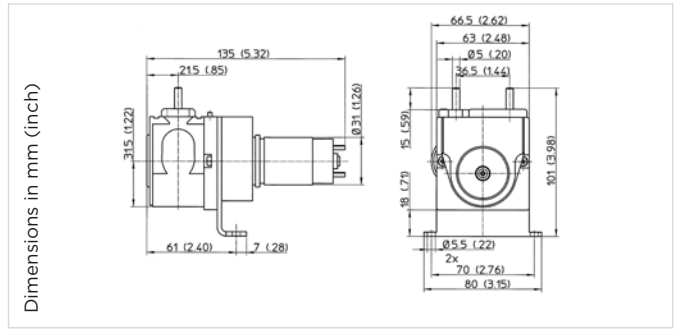
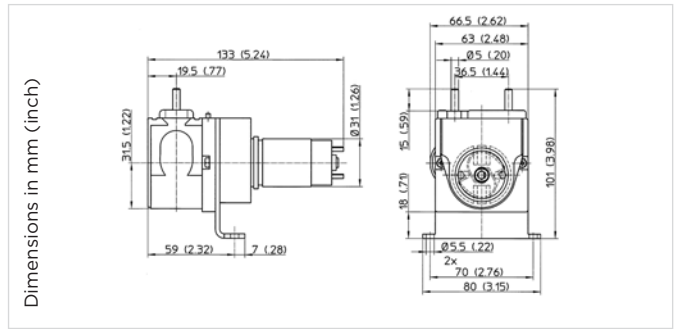

Bore pattern to fit in a housing see page 14.

Nominal speed					
	10 rpm	30 rpm	65 rpm	80 rpm	170 rpm ¹⁾

Tubing Novoprene		Flow ²⁾ ml/min			
N 1.6 x 1.6 mm	2	7			
Part number 12 V		20251397			
Part number 24 V	20251388	20251401			
N 3.2 x 1.6 mm	8.4	25	56		
Part number 12 V		20251398	20251411		
Part number 24 V	20251371	20251255			
N 4.1 x 1.6 mm		36	82	102	204
Part number 12 V		20251399	20250083		20251261
Part number 24 V		20251402	20250082	20251010	20250396
N 4.8 x 1.6 mm	17	48	125	132	285
Part number 12 V		20251400	20250426		20251224
Part number 24 V	20251247	20251403	20251413	20250287	20250130

Tubing Silicone		Flow ²⁾ ml/min			
S 2.0 x 1.0 mm	3.5				
Part number 12 V					
Part number 24 V	20251394				
S 3.0 x 1.5 mm	6.5	19			
Part number 12 V		20251405			
Part number 24 V	20251395	20251408			
S 4.0 x 1.5 mm	13	38		103	
Part number 12 V		20250302			
Part number 24 V	20251396			20251434	
S 5.0 x 1.5 mm	18	54		143	287
Part number 12 V		20251406			20251441
Part number 24 V	20250092	20251366		20251435	20251444

Electrical Data			
Motor	Direct current motor		
Power consumption	2 W	3.5 W	7 W

General Data	
Weight	0.6 kg

1) Pump with counter bearing

2025... Stock programme

Material of tubing connectors:

Tubing Silicone: for all Ø PVC
 Tubing Novoprene: Ø 1.6/3.2 mm - PVC
 Ø 4.1/4.8 mm - PP

Option: Recommended inference suppression according to EN 55011 B (CE-conform)
 12/24 V DC - with additional circuit board (on request)

2) Note: The indicated values are average measured with water. The actual values depend on different parameters like quality and age of tubing, pressure of tubing beds, pressure ratios, viscosity. Please see page 4 for recommended running times and general data.

Peristaltic Pumps SR25

**230 V/50 Hz, shaded pole motor
For short time operation only**

Flow

6 - 746 ml/min

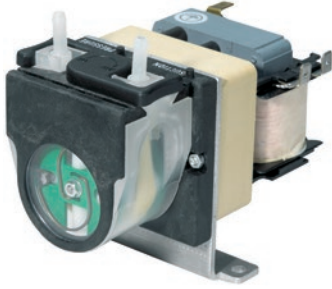

SR25, 30 bis 80 rpm shaded pole motor



SR25 - 500 Upm shaded pole motor ¹⁾

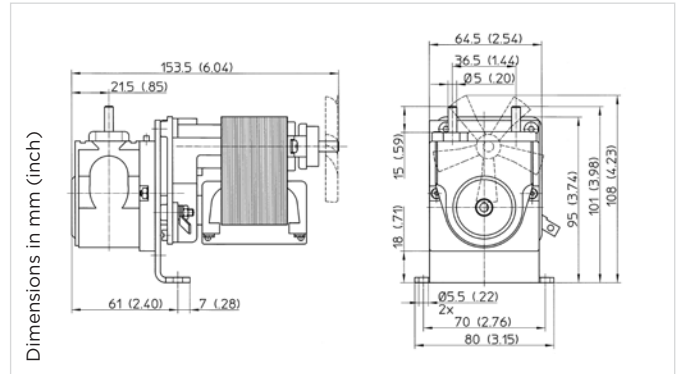
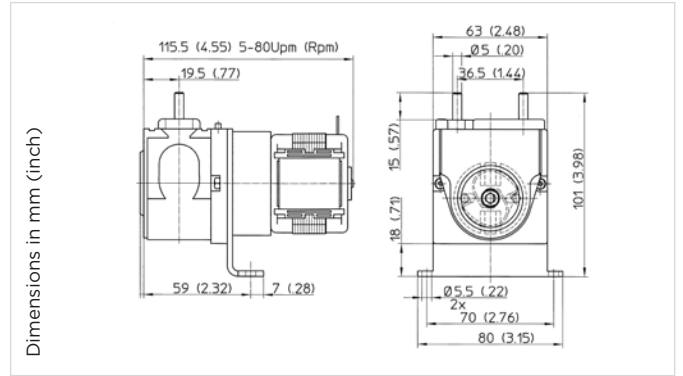

Bore pattern to fit in a housing see page 14.

Nominal speed

	30 rpm	65 rpm	80 rpm	500 rpm ^{1) 3)}
--	--------	--------	--------	--------------------------

Tubing Novoprene

Flow²⁾ ml/min

N 1.6 x 1.6 mm	6	12	15	
Part number	20250009		20250893	
N 3.2 x 1.6 mm	21	47	56	
Part number	20250010		20250892	
N 4.1 x 1.6 mm	30	68	85	545
Part number	20250881	20250886	20250891	
N 4.8 x 1.6 mm	40 ²⁾	90	110	690
Part number	20250880	20250884	20250020	20250913

Tubing Silicone

Flow²⁾ ml/min

S 4.0 x 1.5 mm	32	70	86	546
Part number	20251280	20250888		
S 5.0 x 1.5 mm	45	88	119	746
Part number	20250047	20250887	20250057	20250919

Electrical Data

Voltage	230 V/50 Hz	230 V/50 Hz
Motor	Shaded pole motor	Shaded pole motor
Power consumption	16 W	68 W
Motor insulation class	E	E

General Data

Protection class	IP00	IP00
Weight	0.7 kg	1.5 kg

1) Pump with counter bearing
3) Fan

2025... Stock programme

Material of tubing connectors:
Tubing Silicone: for all Ø PVC
Tubing Novoprene: Ø 1.6/3.2 mm - PVC
Ø 4.1/4.8 mm - PP

2) Note: The indicated values are average measured with water. The actual values depend on different parameters like quality and age of tubing, pressure of tubing beds, pressure ratios, viscosity. Please see page 4 for recommended running times and general data.

Peristaltic Pumps SR25

230 V/50 Hz, synchronous motor
Suitable for continuous operation

Flow 0.2 – 14 ml/min



SR25, 1 to 10 rpm
Synchronous motor

Bore pattern to fit in a housing
 (not illustrated)

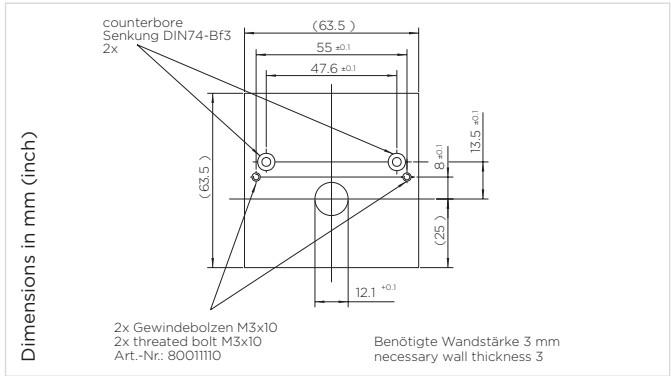
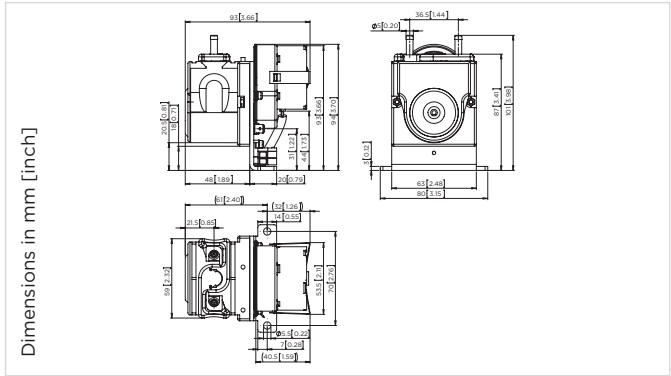

Nominal speed

	1 rpm	5 rpm	10 rpm
--	-------	-------	--------

Tubing Novoprene Flow²⁾ ml/min

N 1.6 x 1.6 mm	0.2		
Part number	20251737		
N 3.2 x 1.6 mm		3.5	7.0
Part number		20251351	20251355
N 4.1 x 1.6 mm	1.0	5.0	10
Part number	20251739	20251352	20251356
N 4.8 x 1.6 mm	1.3	6.8	14
Part number	20251740	20251353	20251357

Electrical Data

Voltage	230 V/50 Hz
Motor	Synchronous
Power consumption	2 W
Motor insulation class	E

General Data

Protection class	IPO0
Weight	0.39 kg

2025... Stock programme

Electrical wiring:

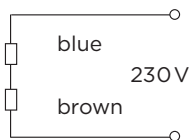

Material of tubing connectors:
 Tubing Novoprene: Ø 1.6/3.2 mm - PVC
 Ø 4.1/4.8 mm - PP

2) Note: The indicated values are average measured with water. The actual values depend on different parameters like quality and age of tubing, pressure of tubing beds, pressure ratios, viscosity. Please see page 4 for recommended running times and general data.

Peristaltic Pumps SR25-S300

24 V DC with stepper motor
Circuit board recommended for test purposes

Flow

0.1 – 430 ml/min

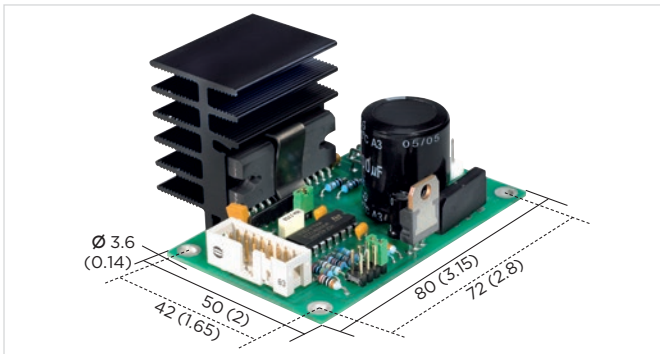

4 possible operating methods

- internal speed selection via jumper
- option with wiring set¹⁾
- external speed selection
- analog input via pc
- digital input (clocked pulse)

Features

- speed pre-selection
- clockwise, counter clockwise operation
- instant priming
- selective operating method

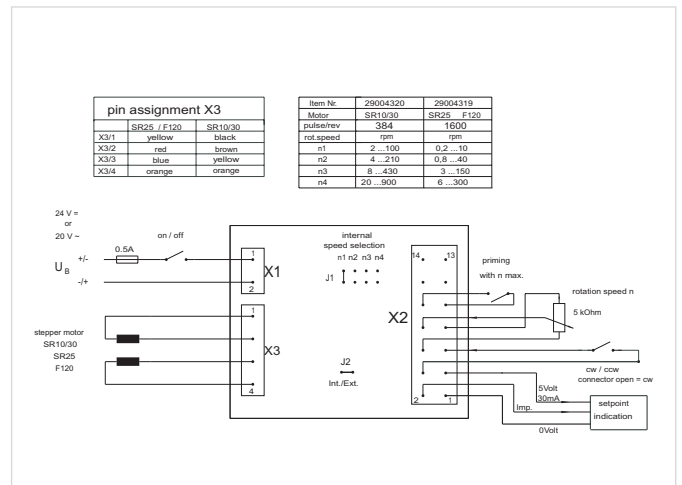
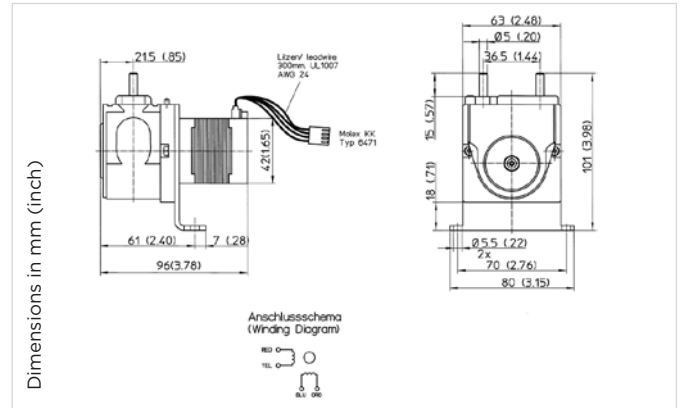

Adjustable range	I	II	III	IV
Speed	0.4 – 10 rpm	1.6 – 40 rpm	6 – 150 rpm	12 – 300 rpm

Tubing Novoprene	Max. flow ²⁾ ml/min			
N 1.6 x 1.6 mm	0.1 – 2	0.3 – 7	1 – 26	2 – 55
Part number - pump without circuit board	20252200			
Part number - pump with circuit board	20252100			
N 3.2 x 1.6 mm	0.3 – 7	1 – 30	4 – 110	9 – 210
Part number - pump without circuit board	20252201			
Part number - pump with circuit board	20252101			
N 4.8 x 1.6 mm	0.6 – 14	2 – 60	9 – 215	20 – 430
Part number - pump without circuit board	20252202			
Part number - pump with circuit board	20252102			

Running Data	
On-time	Continuous operation
Recommended rotating direction at continuous operation	Clockwise

Electrical Data	
Nominal voltage (drive through electronic board)	24 V/DC oder 20 V/AC
Motor	Stepper motor, bipolar, stepping angle 1.8°
Current consumption	0.8 A
Max. restart consumption	5 A*
Inductance at 1 kHz, 1 V	14 mH
Winding resistance	6 Ω
Motor insulation class	B

General Data	
Material of the hose clip	PVDF
Weight of the pump	0.5 kg

* Delay fuse to be used.

1) Option: 14-pole connecting cable with plug, rocker switch for clockwise and lefthanded running Potentiometer and speed-push-button, part number 29000702

2) Note: The indicated values are average measured with water. The actual values depend on different parameters like quality and age of tubing, pressure of tubing beds, pressure ratios, viscosity. Please see page 4 for recommended running times and general data.

Peristaltic Pumps SR25

Spare parts SR25

Tubing with connectors



Tubing	Diameter x wall thickness	Connectors	Part number
Novoprene	1.6 x 1.6 mm	PVC	92025500
Novoprene	3.2 x 1.6 mm	PVC	92025501
Novoprene	4.1 x 1.6 mm	PE	92025502
Novoprene	4.8 x 1.6 mm	PE	92025503
Test-set with all tubings			92025856
Silicone	2.0 x 1.0 mm	PVC	92025507
Silicone	3.0 x 1.5 mm	PVC	92025508
Silicone	4.0 x 1.5 mm	PVC	92025509
Silicone	5.0 x 1.5 mm	PVC	92025532
Test-set with all tubings			92025857
Option			
PharMed BPT®	4.0 x 1.6 mm	PVDF	92025849
PharMed BPT®	4.8 x 1.6 mm	PVDF	92025843
Novoprene	1.6 x 1.6 mm	PVDF	92025552
Novoprene	3.2 x 1.6 mm	PVDF	92025533
Novoprene	4.1 x 1.6 mm	PVDF	92025549
Novoprene	4.8 x 1.6 mm	PVDF	92025563

Roller carrier

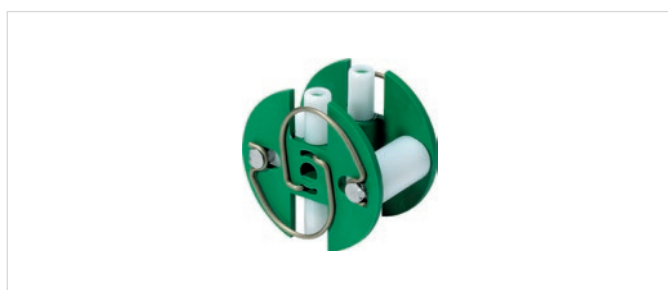

Speed	SR25 AC	SR25 12 V DC	SR25 24 V DC	SR25 Synchron
1 rpm	-	-	-	92025799 ²⁾
5 rpm	-	-	-	92025799 ²⁾
10 rpm	-	-	92025804 ¹⁾	92025799 ²⁾
30 rpm	92025803 ¹⁾	92025803 ¹⁾	92025803 ¹⁾	-
65 rpm	92025803 ¹⁾	92025803 ¹⁾	92025803 ¹⁾	-
80 rpm	92025803 ¹⁾	-	92025803 ¹⁾	-
170 rpm	92025801 ¹⁾	92025806 ¹⁾	92025806 ¹⁾	-
300 rpm	-	-	92025801 ¹⁾ (Steppermotor)	-
500 rpm	92025801 ¹⁾	-	-	-

Pump body with clamp



Speed	Type	Part number
1 - 10 rpm	SR25 Synchr.	92025625 (Counterbearing)
10 - 80 rpm	SR25 AC/DC	92025630
170 - 500 rpm	SR25 AC/DC	92025625 (Counterbearing)

Rolling band



Part number
29008965

Clamp



Part number
29020480

1) Clockwise direction
2) Counter clockwise direction

Peristaltic Pumps

Tubing Properties		
Tube	Characteristics	Limitations
Novoprene	Standard tubing for the SR10/30, SR10/50 and SR25 Long lifetime Wide range of applications	May swell up with oil or oily liquids
Norprene®	Standard tubing for the SR10/100 Long lifetime Suitable especially for alkaline solutions	
PharMed BPT®	High quality for medical, laboratory and research use Homogeneous structure and therefore comparatively better chem. resistance Autoclavable Biocompatible Long lifetime	Expensive
Silicone	Suitable for polar solvents (with the exception of chlorinated aliphatic and aromatized hydrocarbon) No detachment of softening agents Very stable elasticity over a wide temperature range (-30 bis 180 °C)	Not recommended with strong acids or alkaline solutions Swells up in many organic solutions

Choice of tubing depending on flow medium					
		Novoprene	Norprene®	PharMed BPT®	Silicone
Acids	weak medium strong		very good good not recommended		good unsatisfactory not recommended
Alkaline solution	weak medium strong	very good good not recommended		very good very good good	good unsatisfactory not recommended
Hydro-carbons	aliphatic aromatized halogenated		not recommended		
Standards/physiological behaviour		basis material meets FDA (21 CFR 177.2600) doesn't fulfill the EU food requirement 2002/72/EC	not recommended for food, drinks or medicine	USP, class VI FDA (21 CFR 177.2600) NSF	physiologically inert
Chemical structure		thermoplastic elastomer on PP-Basis with cross linked EPDM parts	thermoplastic elastomer on PP-Basis	thermoplastic elastomer on PP-Basis	high cross linked Polysiloxane with anorganic fillers

Peristaltic Pumps

Chemical Resistance of Tubing Materials								
N = Novoprene Nor = Norprene* Ph = PharMed BPT* S = Silicone								
	N	Ph/Nor	S		N	Ph/Nor	S	
Acetaldehyde	C	C	C	Hydrogen peroxide	A	A	C	
Acetate	C	B	D	Hydrogen sulphide	A	A	C	
Acetic acid	A	A	A	Isopropyl alcohol	A	B	A	
Acetic anhydride	A	A	C	Jodine	A	A	C	
Acetone	C	C	A	Kaliumhydroxyde	A	A	C	
Aluminium chloride	A	A	D	Ketones	C	C	-	
Aluminium sulfate	A	A	A	Lactic acid	A	A	C	
Ammonia	A	A	C	Magnesium chloride solution	A	A	A	
Amyl acetate	C	B	C	Mercury salts	A	A	C	
Amyl alcohol	A	C	C	Methanol	A	A	A	
Amyl chloride	C	C	C	Methyl ethyl ketone	B	C	C	
Aniline	A	B	C	Nitrous acid 10 %	B	A	C	
Aqua regia	C	C	C	Oil, animal	B	B	B	
Arsenic acid	C	C	A	Oil, hydraulic	C	C	D	
Barium hydroxide	A	A	A	Oil, linseed	B	B	A	
Benzaldehyde	C	C	C	Oil, mineral	C	C	C	
Benzene	C	C	C	Oil, vegetable	C	B	A	
Benzoic acid	A	B	B	Oleic acid	C	C	C	
Benzylalcohol	-	A	B	Oxalic acid	B	B	B	
Bleaching agent	B	A	A	Paraffins	C	C	-	
Boric acid	A	A	A	Perchloric acid	C	C	C	
Break liquid	A	A	A	Perchloroethylene	C	C	C	
Bromine	C	C	C	Petrol	C	C	C	
Butane	A	A	C	Phenol	A	A	C	
Butanol	B	C	C	Phosphoric acid, 25 %	A	A	C	
Calcium hypochlorite	A	A	B	Photographic solutions	B	B	A	
Carbon disulphide	C	C	C	Phtalic acid, 9 %	-	A	A	
Chloracetic acid	A	B	-	Potassium salts	A	A	A	
Chlorine, liquid	C	C	C	Pyridine	C	C	C	
Chlorobenzene	C	C	C	Soap solution	A	A	A	
Chloroform	C	C	C	Sodium carbonate	A	A	A	
Chromic acid 50 %	C	C	C	Sodium chloride	A	A	A	
Chromium salts	A	A	C	Sodium hydroxide 40 %	A	A	B	
Citric acid	B	B	A	Sodium hypochlorite <5%	A	A	B	
Cyclohexane	C	C	C	Sodium hypochlorite 12 %	A	A	B	
Diesel fuel	C	C	C	Sodium salt	A	A	A	
Ethanol	A	A	C	Stearic acid, 5 %	B	A	B	
Ether	C	C	C	Sulphurdioxide, wet gas	A	A	B	
Ethyl alcohol	A	A	A	Sulphuric acid, 30 %	A	A	C	
Ethyl chloride	A	A	C	Sulphuric acid, 75-100%	C	C	C	
Ethylene glycol	-	A	A	Sulphurtrioxide	-	B	-	
Ferric sulfate	A	A	A	Tannic acid	A	B	A	
Fluor silicium acid	C	C	-	Tetrahydrofurane	C	C	C	
Fluoroboric acid, 48 %	B	B	-	Toluole	C	C	C	
Formaldehyde	B	C	B	Trichloroethylene	B	B	C	
Formamide	A	B	-	Turpentine	C	C	C	
Formic acid	A	B	A	Urea	A	A	A	
Furfural	C	C	-	Uric Acid	A	A	-	
Hydrochloric acid	A	A	C	Xylene	C	C	C	
Hydrocyanic acid	A	A	C	Zinc chloride	B	B	B	

A = small or no effect

B = minor or moderate effect

C = severe effect

D = no reliable data, please test before use

- = no available data

Norprene®, PharMed BPT®, Norton Co. Reg. TM's,

The material resistance is influenced by temperature and concentration of the medium.

The data have to be seen as indications and do not guarantee the material properties.

PUMP AND COMPRESSOR SOLUTIONS FOR OEMS WORLDWIDE

gd-thomas.com



Gardner Denver Thomas GmbH
Livry-Gargan-Str. 10
82256 Fürstenfeldbruck
Germany
T +49 8141 2280 0
F +49 8141 8892136
thomas.de@gardnerdenver.com

Gardner Denver Hong Kong, Limited
Unit 1317-1318 Delta House, 3 On Yiu Street
Siu Lek Yuen, Shatin, New Territories
Hong Kong
T +852 26903502
F +852 27924598
thomas.hk@gardnerdenver.com

Gardner Denver Thomas, Inc.
1419 Illinois Avenue
Sheboygan, WI 53081
USA
T +1 920 4574891
F +1 920 4514276
td.usa@gardnerdenver.com

THOMAS
by Gardner Denver

The information presented in this material is based on technical data and test results of nominal units. It is believed to be accurate and reliable and is offered as an aid to help in the selection of Thomas products. It is the responsibility of the user to determine the suitability of the product for the intended use and the user assumes all risk and liability in connection therewith. Thomas does not warrant, guarantee or assume any obligation or liability in connection with this information.

Models presented in this catalog are representative of the product family. Photos of products pictured in this catalog do not necessarily represent a specific model number. To obtain further information for custom options, contact your local Thomas office.

Printed in Germany Form No. 17000056 06/2016 © Gardner Denver Thomas GmbH. All rights reserved.